



Manhole Products

**96" Type 2 Precast Catch Basin
WSDOT B-10.20-03**

Square Risers Available

- 2", 3", 4", 6", 12", 24" Solid or w/ Knockouts

Grade Adjustment Rings Available

- 2", 3", 4", 6"

Hole or Knock Out Dimensions

- Maximum hole size is 84 inches
- 12 inches of minimum distance between holes
- 3 inch diameter lifting holes provided
- Cored, cast-in and custom block-out/knock-outs available

Conformity Standards

- ASTM C478 Manhole
- ASTM C443 rubber gasket joint
- ASTM D4101 polypropylene steps and ladders
- Washington State APWA / WSDOT Standard

Options Available

- 2 foot minimum sump
- Specialized coatings
- Custom hatches
- Kor-N-Seal boots
- 1' thru 10' Polypropylene ladders
- Round offset & center hole flat tops
- Mastic

Section Specifications

Height Section

12"	2,954 LBS
24"	5,973 LBS
36"	8,992 LBS
48"	12,010 LBS
60"	15,029 LBS
72"	18,048 LBS
84"	21,067 LBS
96"	24,077 LBS

Base Slab	Flat Top
9,955 LBS	10,675 LBS

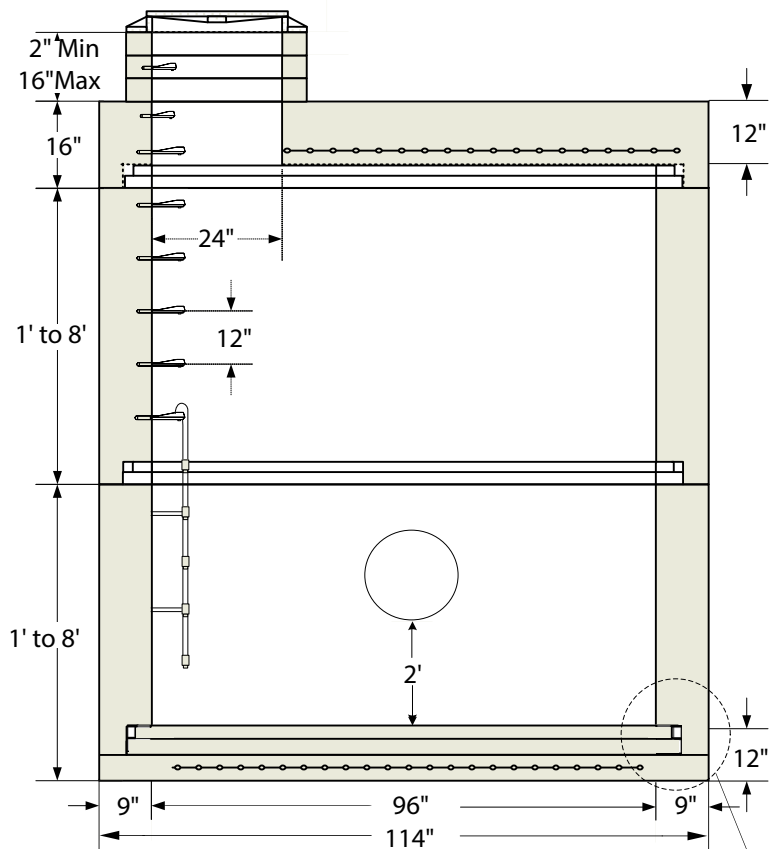

Top Slab Plan View

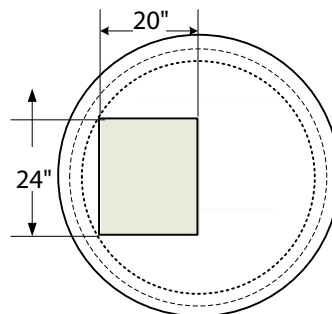

Gasket Shown Uncompressed

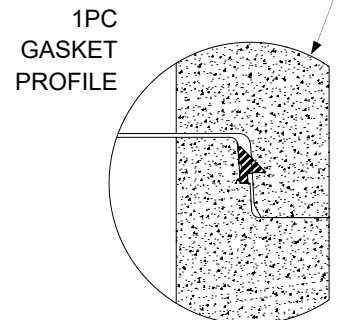

Note: Drawings not to scale

www.shopeconcrete.com

1-800-422-7560 [TOLL FREE]



Shope Concrete, LLC
1618 East Main Avenue
Puyallup, WA 98372-3142

(253) 848-1551
Fax Line 1 (253) 845-0292
Fax Line 2 (253) 864-6172

